

CW-98G

90

GAS CHARCOAL GRILL

Charcoal grill gas on open cabinet - N. 2 stainless steel adjustable grills cm. 38x66 - 2 cooking areas (included 1 Head end filler strip mod.TPA-9)



Construction - Fabricated using CrNi 18/10 AISI 304 grade Stainless Steel Scotch-Brite Satin polish Finish, incorporating 2mm thick worktop, rounded edges, chromed details and rear splash back. Knobs with waterproof grades IPX5. Model - Professional Gas Charcoal Grill, on open cabinet. Grill container for holding Lava Rock over burners. Burners with Piezoelectric ignition and pilot light, thermocouple safety valves, Removable liquid containers. Maintenance - All serviceable parts are accessible by the easy removal of front control panel. Fittings - Appliance is supplied with both LPG and Natural Gas conversion jets and adjustable feet. Doors not included.



ITALIAN CULINARY ART

The pictures are purely representative. The manufacturer reserves the right to modify the technical data and models without previous notice.

CW-98G

90

GAS CHARCOAL GRILL

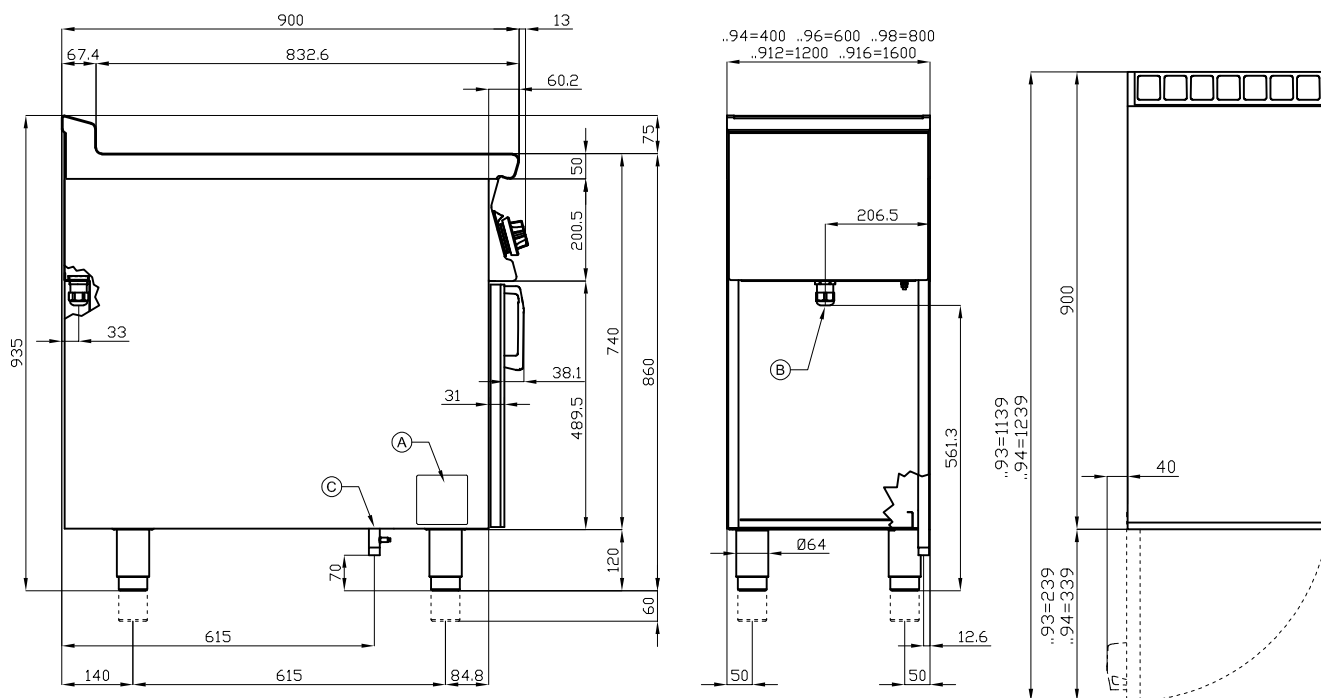

A	Data plate	C	Gas connection ISO 7-1 1/2" M
---	------------	---	----------------------------------

MODEL: CW-98G
DIMENSIONS: cm. 80x 90x 90h
GAS POWER: 24 kW / 20.640 kcal/h
GAS TYPE: Natural Gas / LPG



kg: 131
m³: 0.894
mm: 830x970x1110

BUY LOTUS BUY ITALY

The pictures are purely representative. The manufacturer reserves the right to modify the technical data and models without previous notice.



LOTUS S.P.A. Via Calmaor, 46
 31020 San Vendemiano(TV) - Italy
 Tel. + 39 0438 778020 / 778468
 Fax + 39 0438 778277
 www.lotuscookers.it - lotus@lotuscookers.it